

Orientation Contrast Sensitive Cells in Primate V1

A Computational Model

Tino Lourens (tino.lourens@philips.com)

Philips Medical Systems Nederland B.V., Veenpluis 4-6, 5680 DA, Best, The Netherlands

Emilia Barakova (e.i.barakova@tue.nl)

Technical University of Eindhoven, Den Dolech 2, 5612 AZ, Eindhoven, The Netherlands

Abstract. Many cells in the primary visual cortex respond differently when a stimulus is placed outside their classical receptive field (CRF) compared to the stimulus within the CRF alone, permitting integration of information at early levels in the visual processing stream that may play a key role in intermediate-level visual tasks, such a perceptual pop-out (Knierim and van Essen, 1992; Nothdurft et al., 1999), contextual modulation (Levitt and Lund, 1997; Das and Gilbert, 1999; Dragoi and Sur, 2000), and junction detection (Sillito et al., 1995; Das and Gilbert, 1999; Jones et al., 2002). In this paper we construct a computational model in programming environment TiViPE (Lourens, 2004) of orientation contrast type of cells and demonstrate that the model closely resembles the functional behavior of the neuronal responses of non orientation (within the CRF) sensitive $4C\beta$ cells (Jones et al., 2002), and give an explanation of the indirect information flow in V1 that explains the behavior of orientation contrast sensitivity. The computational model of orientation contrast cells demonstrates excitatory responses at edges near junctions that might facilitate junction detection, but the model does not reveal perceptual pop-out.

Keywords: early vision, V1, orientation contrast cells, TiViPE simulation

1. Introduction

Neurons in the primary visual cortex (V1) respond in well defined ways to stimuli within their classical receptive field (CRF), but these responses can be modified by additional peripheral stimuli. The size of the periphery (non classical surround) provides input from a larger portion of the visual scene than originally thought, permitting integration of information at early levels in the visual processing stream. Neuronal responses in V1 to static texture patterns are suppressed by textured periphery, while these cells tended to respond more strongly to a stimulus in which there was a contrast in orientation between center and surround compared to a stimulus lacking such contrast (Knierim and van Essen, 1992).

Recent works indicate that neuronal surround modulation at cross-orientation, an orientation orthogonal to the preferred orientation of

the classical receptive field, might play a key role in intermediate level visual tasks, such as perceptual pop-out (Knierim and van Essen, 1992; Nothdurft et al., 1999), contrast facilitation (Cavanaugh et al., 2002; Yu et al., 2002), and contextual modulation (Levitt and Lund, 1997; Das and Gilbert, 1999; Dragoi and Sur, 2000). The strength of this contextual influence on a neuron can be predicted from a model of local connection based on simple overlap with particular features, which indicates that local intra cortical circuitry could endow neurons with a graded specialization for processing angular visual features such as corners and junctions (Sillito et al., 1995; Das and Gilbert, 1999; Jones et al., 2002).

Depending on the orientation of an inner and outer grating pattern, these neuronal cells have the tendency to respond strongly to a center orientation preference or orientation contrast¹ between inner and outer pattern. Neuronal output activity was enhanced in both cat and macaque primary visual cortex (V1) when, a surrounding field at a significantly different orientation (30 degrees or more) was added to the preferred orientation of the classical receptive field (Sillito et al., 1995). Cells in layer $4C\beta$, which are non-orientation sensitive within their CRF, also show these response profiles indicating that there must be a strong feedback from other areas (within V1) that create these more complex profiles. We assume that these cells obtain feedback from complex cells in layers 2, 3, 5, and 6 of V1. The aim of this paper is to setup a computational model of this type of cells which we will term *orientation contrast cells*, and to simulate these cells in visual programming environment TiViPE (Lourens, 2004).

The paper is organized as follows: Section 2 elaborates on the properties of non orientation tuned cells with respect to orientation contrast, their pathway in early vision, and provides a computational model. Section 3 gives a TiViPE simulation that provides the results of this model when applied to the stimuli given by Jones et al (Jones et al., 2002). The paper finishes with a discussion.

2. Non orientation tuned cells

In primate V1 cells 94 percent had a response to orientation contrast stimuli that exceeded the response to the inner stimulus alone, independent from the diameter of the surround patch, while the responses

¹ Orientation contrast is the difference between preferred orientation of a center patch (which roughly covers the CRF) and preferred orientation of a surround patch (outside the CRF). This contrast is strongest when the center and surround orientations are orthogonal and weakest when both are the same.

were somewhat inhibitory when the orientation of the inner and outer stimuli were the same, compared to the response to the inner stimulus alone (Jones et al., 2002). They found that the responses of $4C\beta$ cells could be modulated by varying both orientation of a center grating patch (inside the CRF) and a surround grating patch (outside the CRF), despite the cell's lack of orientation tuning within the CRF. Its response output was extremely sensitive to orientation differences between center and surround patches.

The LGN parvo cellular cells (P) have center-surround shaped receptive field profiles which optimally respond to a spot of light. In a feed-forward processing stream one could expect a similar receptive field type in layer $4C\beta$. For instance, a set of center-surround profiles that are aligned in a certain way, may respond strongly to a line or bar of a specific orientation. However, such profile does not provide center orientation preference nor is it able to provide a measure for center-surround orientation contrast. The modulation of its response behavior must be caused by an indirect (feedback loop) information stream, as illustrated in Figure 1. The local feedback connections from deep layers (5 and 6) arise from a diverse population of pyramidal neurons. Each type forms local connections with a unique relationship to more superficial layers. In the case of layer 6 neurons, these connections are closely related to layer 4 subdivisions receiving input from different functional streams (Callaway, 1998; Sillito et al., 2006).

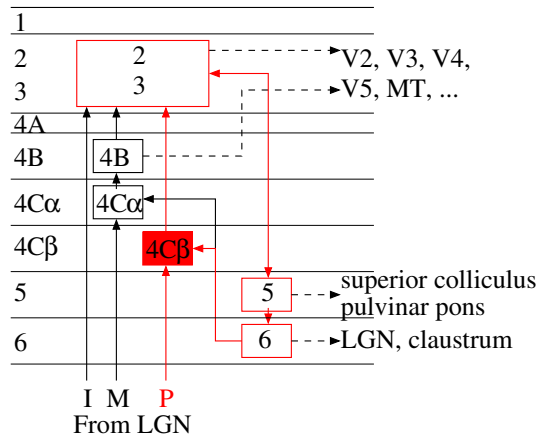

Figure 1. Information flow in the primary visual cortex (V1) based on anatomical connections (Kandel et al., 2000).

2.1. ORGANIZATION OF THE PRIMARY VISUAL CORTEX

The primary visual cortex (V1) consists of six layers (1-6) between the pial surface and the underlying white matter. The principal layer for inputs from the lateral geniculate nucleus (LGN) is layer 4, which is subdivided into four sub layers (4A, 4B, 4C α , and 4C β), see also Figure 1. This flow can be described by means of input, intra cortical, and output connections (Kandel et al., 2000):

- **Inputs.** Axons from magno cellular (M) and parvo cellular (P) cells in the lateral geniculate nucleus (LGN) end on spiny stellate cells in the sub layers of 4C, and these cells project axons to layers 2, 3, or 4B. Axons from cell in the intra laminar (I) zones of the LGN project directly to layers 2 and 3.
- **Intra cortical connections.** Axon collaterals of the pyramidal cell in layers 2 and 3 project to layer 5 pyramidal cells, whose axon collaterals project both to layer 6 pyramidal cells and back to cells in layers 2 and 3. Axon collaterals of layer 6 pyramidal cells then make a loop back to layer 4C onto smooth stellate cells.
- **Outputs.** Each layer, except for 4C, has outputs and each is different. Cells in layers 2, 3, and 4B project to extra striate visual cortical areas. Cells in layer 5 project to the superior colliculus, the pons, and pulvinar. Cells in layer 6 project to claustrum and back to the LGN.

The assumption that a 4C β cell receives input from simple (layer 2) or complex cells (layer 3) through layers 5 and 6 makes it plausible that these cells have a far more complex receptive field profile than one can expect from a feed-forward mechanism alone.

2.2. ORIENTATION SENSITIVE INPUT RESPONSES

In order to model the profiles suggested by (Jones et al., 2002) we assume that layer 4C β receives complex cell (indirect) input from layers 2, 3, 5, and 6. A computational model of simple and complex cells (Lourens, 1998; Würtz and Lourens, 2000) is used to form the input of the orientation contrast cells and is introduced only briefly.

The receptive fields of simple cells can be modeled by complex valued Gabor functions:

$$\hat{G}_{\sigma,\theta}(x, y) = \exp\left(i \frac{\pi x_1}{\sqrt{2}\sigma\lambda}\right) \exp\left(-\frac{x_1^2 + \gamma^2 y_1^2}{2\sigma^2}\right), \quad (1)$$

where $i = \sqrt{-1}$, $x_1 = x \cos \theta + y \sin \theta$ and $y_1 = y \cos \theta - x \sin \theta$. Parameters σ , λ , γ , and θ represent scale, wavelength, spatial aspect ratio, and orientation, respectively. These Gabor functions have been modified, such that their integral vanishes and their one-norm (the integral over the absolute value) becomes independent of σ , resulting in $G_{\sigma,\theta}(x, y) = \eta \widehat{G}_{\sigma,\theta}(x, y)$, where $\eta = \eta_{\text{Re}}^+$ for the positive valued real part of \widehat{G} , $\eta = \eta_{\text{Re}}^-$ for the negative valued real part of \widehat{G} , and $\eta = \eta_{\text{Im}}$ for the imaginary part of \widehat{G} . For details about these constants see (Lourens, 1998). A spatial convolution was used to transform input image $I(x, y)$ by these operators to yield the simple cell operator, and the amplitude of the complex values (Morrone and Burr, 1988)

$$\mathcal{C}_{\sigma,\theta} = ||I * G_{\sigma,\theta}|| \quad (2)$$

was taken to obtain the complex cell operator.² This operator forms the basis of the orientation contrast cell operator \mathcal{O} to be described later in this paper. A high value at a certain combination of (x, y) and θ represents evidence for a contour element (bar or edge) oriented orthogonally to θ . Orientations are sampled linearly $\theta_j = \pi/N, j = 0, \dots, N-1$, and the scales are sampled $\sigma_k = \sigma_{k-2} + \sigma_{k-1}$, for $k = 2 \dots S-1$, where σ_0 and σ_1 represent constants.

2.3. ORIENTATION CONTRAST AND CENTER ORIENTATION PREFERENCE

Neuronal cells in area V1 respond to both orientation contrast and center orientation. Depending on the size and orientation of the peripheral patch compared to the preferred orientation of the center patch (which covers the CRF) the response is inhibitory or excitatory. When the patch is similar in size compared to its center patch, the cell tends to respond strongly to orientation contrast, while a patch that has a diameter of four times the diameter of the central patch tends to respond strongly to the preferred orientation of the central patch (Jones et al., 2002). These findings suggest a varying gain value that depends on the size of the surround patch. This is modeled as follows:

$$G_x(s) = \left[-\frac{2s^2}{30} - \frac{s}{10} + \frac{2}{3} \right]^{\geq 0}, \quad (3)$$

where s denotes the surround patch diameter in degrees, and $[x]^{\geq 0} = x$ if $x \geq 0$ and 0 otherwise. The curve obtained by varying the surround patch diameter is illustrated in Figure 2a.

² The preferred orientation $\theta \in [0, \pi)$, since $\mathcal{C}_{\sigma,\theta} = \mathcal{C}_{\sigma,\theta+\pi}$.

The normalized response profile (weight matrix) is modeled as a blend between orientation contrast preference and preferred center orientation:

$$W(c_p, c_o, c_s, s_o, s_s) = G_x(s_s/c_s)X(c_o, s_o) + G_c C(c_p, c_o), \quad (4)$$

where c_p , c_o , and c_s denote the preferred orientation, used orientation, and diameter of the center patch, all between 0 and 360 degrees. Likewise s_o , and s_s denote the used orientation and diameter of the surround patch. The normalized orientation contrast profile is as follows:

$$X(c_o, s_o) = \begin{cases} 0.5 - 0.5 \cos\left(\frac{|c_o - s_o|\pi}{W_x}\right) & \text{if } \alpha_X(c_o, s_o) \leq W_x \\ 1 & \text{otherwise} \end{cases}, \quad (5)$$

where $W_x = 90$ degrees is a constant, and

$$\alpha_X(c_o, s_o) = \min(|c_o - s_o|, |360 + c_o - s_o|, |360 + s_o - c_o|).$$

The normalized preferred center orientation is

$$C(c_p, c_o) = \begin{cases} 0.5 \cos\left(\frac{|c_p - c_o|\pi}{W_c}\right) + 0.5 & \text{if } \alpha_C(c_p, c_o) \leq W_c \\ 0 & \text{otherwise} \end{cases}, \quad (6)$$

where $W_c = 90$ degrees is a constant, and

$$\alpha_C(c_p, c_o) = \min(|c_p - c_o|, |360 + c_p - c_o|).$$

The response of the $4C\beta$ cell as measured by (Jones et al., 2002) in Figure 6 shows a maximum response of around 70 while the minimum response is around 15. To obtain the response profile as given in Figure 2b-d the following response was used:

$$R_W = 70(W + 0.2). \quad (7)$$

2.4. ORIENTATION CONTRAST CELL OPERATOR

The response of a center patch which covers the CRF is obtained as follows:

$$\mathbf{C}_{\sigma, c_s} = \mathcal{C}_{\sigma, \theta_i} * g_{c_s/6}, \quad (8)$$

where $\theta_i = i\pi/N$, $i = 0, \dots, N$, and

$$g_\sigma(x, y) = \frac{\exp\left(-\frac{x^2 + y^2}{2\sigma^2}\right)}{2\pi\sigma^2}$$

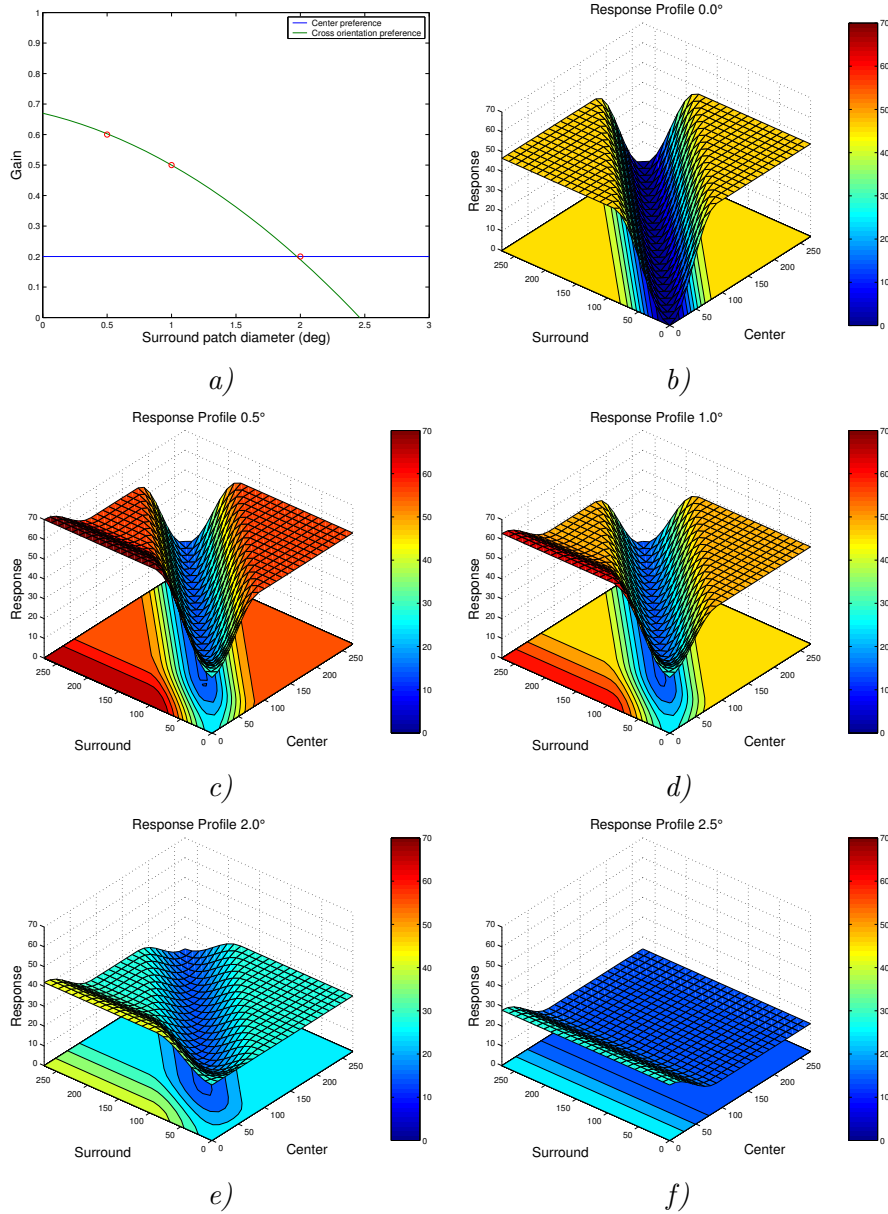

Figure 2. Modeled response profiles (7) of a non orientation tuned layer $4C\beta$ cells to varying the orientation of both center and surround patch, for a comparison with the measured responses, see Fig. 6 of (Jones et al., 2002). *a)* Blending curve between orientation contrast and center orientation preference. *b)* Modeled profile for $s_s = 0$, which gives solely a preference to orientation contrast. *c-e)* Profiles for $s_s = 0.5, 1.0,$ and 2.0 degrees, respectively. *f)* Modeled profile for $s_s \geq 2.5$, which solely prefers the center orientation. Parameters used are preferred center orientation $c_p = 0$ degrees, and center radius $c_s = 0.5$ degrees.

is a 2D Gaussian function.

The response of a surround patch is obtained by taking the maximum response of differently sized surround patches

$$\mathbf{S}_{\sigma, c_s, s_{\min}, s_{\max}, Q} = \max_{(x1, y1)} (W(c_p, c_o, c_s, s_o, s_s) - W_s) \max_j \left(\widehat{\mathcal{C}}_{\sigma, \theta_i}(x1, y1) \right), \quad (9)$$

where

$$\begin{aligned} \widehat{\mathcal{C}}_{\sigma, \theta_i} &= \mathcal{C}_{\sigma, \theta_i} * g_{s_{s_j}/6} \\ s_{s_j} &= s_{\min} + j \frac{s_{\max} - s_{\min}}{Q - 1} \end{aligned}$$

has a linearly increasing patch size between s_{\min} and s_{\max} , $j = 0, \dots, Q-1$, and Q is the number of surround patch sizes. Let j_{\max} denote the index j for which holds $\widehat{\mathcal{C}}_{\sigma, \theta_i}$ is maximal. Weight W from (4) is in the 0 to 90 degree range, since we assume that the grating pattern is static rather than moving in a specific direction, W_s is an inhibitive weight, and $(x1, y1)$ are the spatial positions of the outer stimulus. Since these patches largely overlap resampling is used to reduce computational time. Preferred center orientation c_p , center orientation c_o , surround orientation s_o , and surround patch size s_s are as follows:

$$c_p = c_o = \begin{cases} 180i/N & \text{if } i \leq N/2 \\ 180(N-i)/N & \text{otherwise} \end{cases} \quad (10)$$

$$s_s = s_{\min} + j_{\max} \frac{s_{\max} - s_{\min}}{Q - 1} \quad (11)$$

$$s_o = \begin{cases} 180j_{\max}/N & \text{if } j_{\max} \leq N/2 \\ 180(N - j_{\max})/N & \text{otherwise} \end{cases} \quad (12)$$

The orientation contrast operator which comprises a center response and a surround response that depends on the center response is as follows:

$$\mathcal{O}_{\sigma, c_s, s_{\min}, s_{\max}, Q} = (\mathbf{C}_{\sigma, c_s} + w \mathbf{S}_{\sigma, c_s, s_{\min}, s_{\max}, Q}) * g_{c_s/6}, \quad (13)$$

where weight $w = \mathbf{C}_{\sigma, c_s}/R$ is a weight that is dependent on the center response \mathbf{C} . In all simulations constant $R = 255$ was used to bound w between 0 and 1.

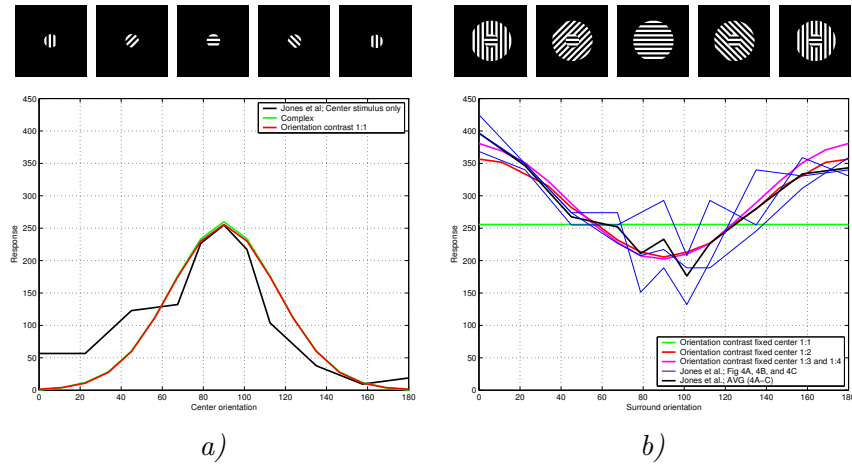

Figure 3. Response characteristics of orientation contrast sensitive cells, see Figure 4A-F from (Jones et al., 2002). *a)* Input stimuli with preferred orientations of 0, 45, 90, 135, and 180 degrees, and below the response profiles to these stimuli of the measured V1 cells, complex cells (\mathcal{C} -operator) and orientation contrast type of cell (\mathcal{O} -operator). *b)* Input stimuli with surround, with preferred center orientation of 90 degrees and varying surround orientation from left to right from 0 to 180 degrees. The ratio between center and surround of these stimuli is 1:3 (top). Response profiles for measured cells and center-only (1:1), and center-surround (1:2, 1:3, and 1:4) stimuli. Responses have been normalized to the maximum response of the modeled complex cells (255). The inhibitory weight $W_s = 0.45$ which yields similar response profiles as the measured V1 cells.

3. Responses to test patterns

The input stimuli used in the simulation have a center radius of 24 pixels and surround radii of 24 (Figure 3a), 48, 72 (Figure 3b), or 96 pixels. The block gratings consist of alternating black and white bars which are both 8 pixels wide. A complex cell operator $\mathcal{C}_{\sigma,\theta}$ with $\sigma = 4\sqrt{2}$ and an orientation θ corresponding to the preferred orientation of the grating pattern yields an optimal response (255), see also Figure 3a, for the complex cell operator \mathcal{C} in the center of the input stimuli of Figure 3a and b. When the center-only input stimulus is applied to orientation contrast operator (\mathcal{O}) for the preferred horizontal center orientation the \mathcal{O} -operator has a very similar response profile compared to the \mathcal{C} -operator, but where the results of \mathcal{C} -operator remain the same, the \mathcal{O} -operator is influenced by its surround as illustrated in Figure 3b (“Orientation contrast fixed center 1:3”). The profile is very similar to the one given by (Jones et al., 2002).

The orientation contrast cell operator \mathcal{O} from (13) has been implemented in visual programming environment TiViPE (Lourens, 2004).

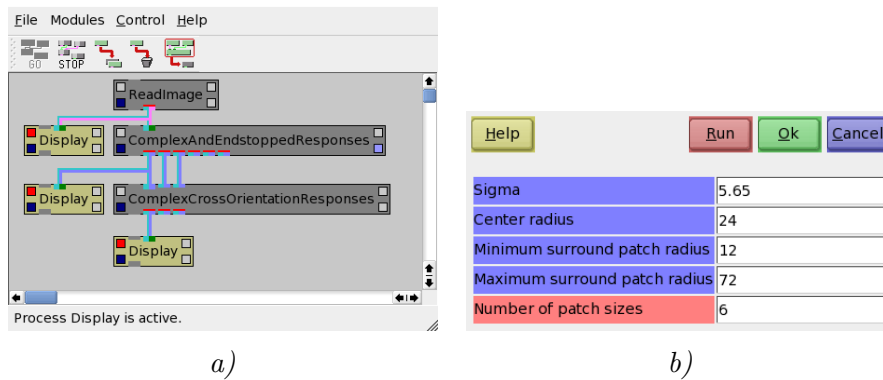

Figure 4. a) TiViPE network. b) Parameters used for cross orientation type of cells.

The orientation contrast simulation that is represented by a network of connected icons consists of a “ReadImage” icon which generates the input stimulus, its connected “Display” icon yields the images provided in Figure 3a and b. The “ComplexAndEndstoppedResponse” produced the responses of the \mathcal{C} -operator (2). Its output forms the input of the “ComplexCrossOrientationResponses” and gives the responses of the \mathcal{O} -operator (13). The values at the center of the two other “Display” icons have been used to construct Figure 3c.

4. The role of orientation contrast cells

Orientation contrast sensitive cells may play a key role in intermediate-level visual tasks, such a perceptual pop-out (Nothdurft et al., 1999), contextual modulation (Levitt and Lund, 1997; Das and Gilbert, 1999; Dragoi and Sur, 2000), and junction detection (Sillito et al., 1995; Das and Gilbert, 1999; Jones et al., 2002).

A simple image (first column of Figure 5a) reveals the properties of the orientation contrast operator proposed in (13). The operator enhances the responses at edges near junctions and decreases the responses at edges otherwise (first column of Figure 5b). If the operator would be applied in a repetitive manner, responses appear only at the edges near junctions, suggesting that they might play a key role in junction detection.

Orientation contrast responses to the bottle image (second column of Figure 5a) also demonstrates that the background at the bottom, left, and right of the bottle is enhanced suggesting that figure-ground segregation can be facilitated. However, neither the response profile in

the second column of Figure 5b nor the difference between orientation-contrast and complex cell responses demonstrate perceptual pop-out effects.

5. Discussion

Many neurons in primary visual cortex (V1) respond differently to a simple visual element presented in isolation compared to when it is embedded in a more complex stimulus. Typically the surround influence was suppressive when the surround grating was at the neuron's preferred orientation (Cavanaugh et al., 2002), but when the orientation in the surround was perpendicular to the preferred orientation facilitation became evident (Sillito et al., 1995; Shevelev et al., 1998; Cavanaugh et al., 2002; Jones et al., 2002). The difference is in the modulation by surrounding elements, hence it could provide neurons with a graded specialization for processing junctions (Sillito et al., 1995; Das and Gilbert, 1999). These neurons also respond to a grating or a single bar of a preferred orientation and are in that respect too general to be purely responding to junctions. In the monkey the majority of cells showed response suppression with increasing grating patch diameter (Born and Tootell, 1991; Sillito et al., 1995) therefore it is likely that a group of these neurons responds to junctions and facilitates pop-out patterns (Knierim and van Essen, 1992; Nothdurft et al., 1999).

The proposed model for orientation contrast cells uses complex cell input that is provided by the indirect pathway from layers 2, 3, 5, and 6 of V1. It is therefore likely that the layer 6 to 4 projection acts as a feedback connection as has been suggested by Callaway (Callaway, 1998). The model yields appropriate characteristics to test patterns as used by Jones et al (Jones et al., 2002) and hence provides evidence that orientation contrast effects in layer 4C β can be adequately explained on the basis of this "feedback" connectivity. This is an issue that has not yet been addressed experimentally in primate V1, because it may not be realistic to carry out controlled experiments to test this hypothesis. Experimental studies in the cat, exploring the role of the corticogeniculate projection from V1 to the lateral geniculate nucleus, provide indirect supporting evidence for this type of feedback. Thus, relay cells in cat lateral geniculate nucleus, that are themselves non-oriented, have also been shown to exhibit orientation contrast effects (Sillito et al., 1993; Sillito and Jones, 2002) and these effects were shown to depend on the feedback projection from cortical V1 layer 6 cells.

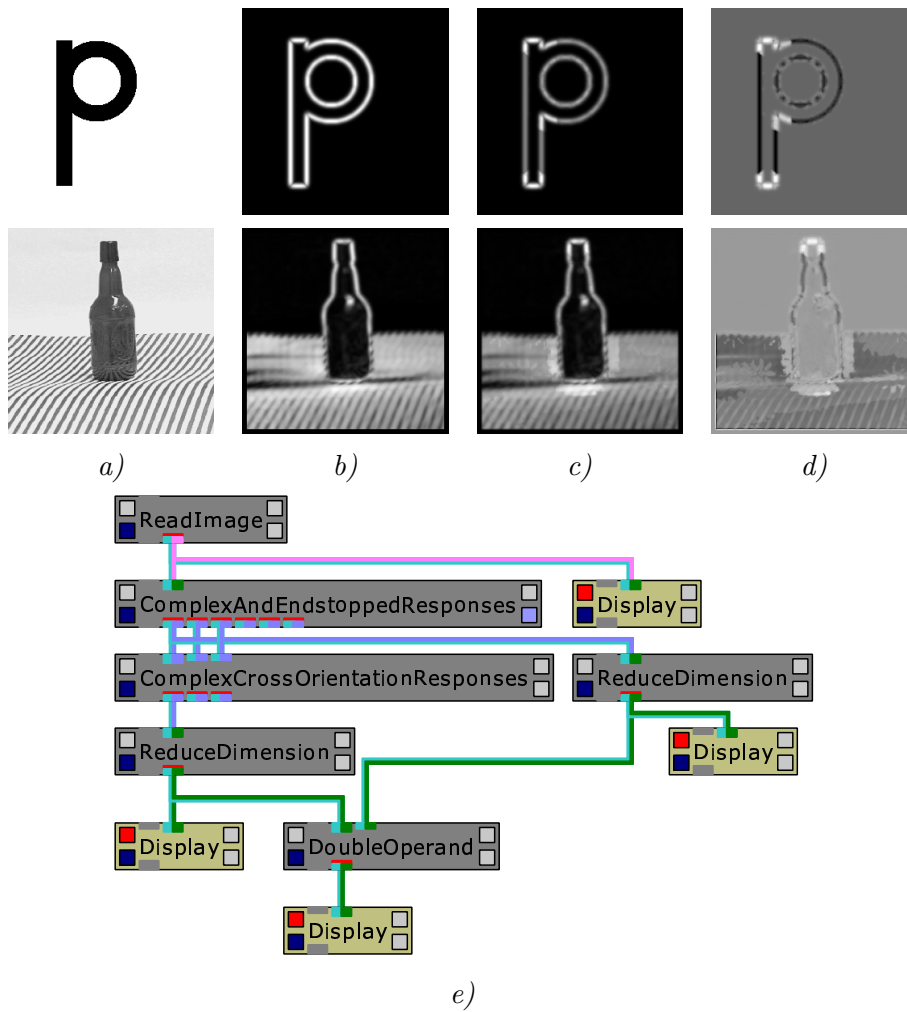

Figure 5. *a)* Input images. *b)* Normalized complex cell responses. *c)* Normalized orientation contrast responses. *d)* Normalized difference in response between complex and orientation contrast responses. White denotes stronger, gray equal, and black weaker response of the orientation contrast cell operator compared to the complex cell operator. *e)* TiViPE simulation. Top, middle, bottom left, and bottom right “Display” icons provide the results given in *a)*, *b)*, *c)*, and *d)*, respectively. The used parameters are $\sigma = 2.82$, a center radius of 4, minimum and maximum surround patch radii of respectively 2 and 12, six different patch sizes, and images of 256x256 pixels.

The current model provides an initial basis for orient contrast type of cells, but Jones et al (Jones et al., 2002) provided more experimental results that could lead to a set of orientation-contrast models with an extended set of properties. The model has not yet been evaluated with natural stimuli, or test stimuli that differ in contrast only. Latter is attractive since the spatial summation properties of most V1 cells vary with stimulus contrast (Sceniak et al., 1999). Future work will include the integration of the model itself into a highly parallel vision system that can be used in intelligent visual devices or a robot in a real world environment.

References

- Born, R. T. and R. B. H. Tootell: 1991, 'Single unit and 2-deoxyglucose studies of side inhibition in macaque striate cortex'. *Proc. Natl. Acad. Sci. USA* **88**, 7071–7075.
- Callaway, E. M.: 1998, 'Local circuits in primary visual cortex of the macaque monkey'. *Annual Review of Neuroscience* **21**, 47–74.
- Cavanaugh, J. R., W. Bair, and J. A. Movshon: 2002, 'Selectivity and Spatial Distribution of Signals From the Receptive Field Surround in Macaque V1 Neurons'. *Journal of Neurophysiology* **88**, 2547–2556.
- Das, A. and C. D. Gilbert: 1999, 'Topography of contextual modulations mediated by short-range interactions in primary visual cortex'. *Nature* **399**, 655–661.
- Dragoi, V. and M. Sur: 2000, 'Dynamic Properties of Recurrent Inhibition in Primary Visual Cortex: Contrast and Orientation Dependence of Contextual Effects'. *Journal of Neurophysiology* **83**, 1019–1030.
- Jones, H. E., W. Wang, and A. M. Sillito: 2002, 'Spatial Organization and Magnitude of Orientation Contrast Interactions in Primate V1'. *Journal of Neurophysiology* **88**, 2797–2808.
- Kandel, E. R., J. H. Schwartz, and T. M. Jessell: 2000, *Principles of neural science*. Mc Graw Hill, fourth edition.
- Knierim, J. J. and D. C. van Essen: 1992, 'Neuronal responses to static texture patterns in area V1 of the alert macaque monkey'. *Journal of Neurophysiology* **67**(5), 961–980.
- Levitt, J. B. and J. S. Lund: 1997, 'Contrast dependence of contextual effects in primate visual cortex'. *Nature*.
- Lourens, T.: 1998, *A Biologically Plausible Model for Corner-based Object Recognition from Color Images*. Maastricht, The Netherlands: Shaker Publishing B.V.
- Lourens, T.: 2004, 'TiViPE –Tino's Visual Programming Environment'. In: *The 28th Annual International Computer Software & Applications Conference, IEEE COMPSAC 2004*. pp. 10–15.
- Morrone, M. C. and D. C. Burr: 1988, 'Feature detection in human vision: A phase-dependent energy model'. *Proc. of the Royal Society of London* **235**, 335–354.
- Nothdurft, H. C., J. L. Gallant, and D. C. V. Essen: 1999, 'Response modulation by texture surround in primate area V1: Correlates of "popout" under anesthesia'. *Visual Neuroscience* **16**, 15–34.

- Sceniak, M. P., D. L. Ringach, and R. Shapley: 1999, 'Contrast's effect on spatial summation by macaque V1 neurons'. *Nature neuroscience* **2**(8), 733–739.
- Shevelev, I. A., N. A. Lazareva, G. A. Sharaev, R. V. Novikova, and A. S. Tikhomirov: 1998, 'Selective and invariant sensitivity to crosses and corners in cat striate neurons'. *Neuroscience* **84**(3), 713–721.
- Sillito, A. M., J. Cudeiro, and H. E. Jones: 2006, 'Always returning: feedback and sensory processing in visual cortex and thalamus'. *Trends in Neuroscience* **29**(6), 307–316.
- Sillito, A. M., J. Cudeiro, and P. C. Murphy: 1993, 'Orientation sensitive elements in the corticofugal influence on centre-surround interactions in the dorsal lateral geniculate nucleus.'. *Exp Brain Res* **1**, 6–16.
- Sillito, A. M., K. L. Grieve, H. E. Jones, J. Cudiero, and J. Davis: 1995, 'Visual cortical mechanisms detecting focal orientation discontinuities'. *Nature* **378**, 492–496.
- Sillito, A. M. and H. E. Jones: 2002, 'Corticothalamic interactions in the transfer of visual information'. *Philos Trans R Soc Lond B Biol Sci* **357**(1428), 1739–1752.
- Würtz, R. P. and T. Lourens: 2000, 'Corner detection in color images through a multiscale combination of end-stopped cortical cells'. *Image and Vision Computing* **18**(6-7), 531–541.
- Yu, C., S. A. Klein, and D. M. Levi: 2002, 'Facilitation of contrast detection by cross-oriented surround stimuli and its psychophysical mechanisms'. *Journal of Vision* **2**, 243–255.

Authors' Vitae

Lourens

Tino Lourens received an MS degree in computer science in 1993 and a PhD degree in 1998, both from the University of Groningen, The Netherlands. He was a researcher at The Netherlands Organization for Applied Scientific Research at The Human Factors Research Institute (TNO-HFRI, 1998-1999), Japan Science and Technology Corporation (JST), ERATO, Kitano Symbiotic Systems Project in Tokyo, Japan (1999-2001), GMD-JRL, Kitakyushu, Japan (2001-2002), and Honda Research Institute (HRI) in Wako, Japan (2003-2006). Currently he is with Philips Medical Systems (PMS). Dr Lourens has published over 40 papers in refereed journals and conferences and is the author of visual programming environment TiViPE. His research interests include: object recognition from real world images, biological models of vision, visual programming, parallel and distributed processing, brain-like computing, multimodal integration, memory, learning, and intelligence.

Barakova

Emilia I. Barakova received a PhD degree in computing science in 1999 from the University of Groningen, The Netherlands. Before that she held research positions at Bulgarian Academy of Science and Central Institute for Computer Technologies in Sofia, Bulgaria, following her MS degree from the TU Sofia in Electronics and Automation Engineering. After her affiliation with the University of Groningen, she has been a researcher at GMD-Japan Research Laboratory and RIKEN Brain Science Institute (currently). In 2001, she was invited to join Starlab, Brussels, Belgium as a senior researcher. Dr Barakova has published over 30 papers in refereed journals and conferences. Her research interests include: behavioral robotics, computational neuroscience, and she has been working on navigation, multimodal integration, learning and memory, perception, and sensory-motor integration.